

## A. Getting started

1. Check all parts against the parts list and inspect for damage.
2. Make sure you have the tools needed for the job.

### Recommended tool list

Adjustable wrench	Torque Wrench	Drill
1/2" wrench (2)	Side Cutter	5/16" drill bit
13/16" wrench	Utility knife	Center punch
7/8" wrench (2)	Adjustable filter wrench	Hammer
15/16" wrench	Drain oil pan	Vice

## B. Filter selection

Any one of 8 different size AMSOIL Full-Flow Oil Filters may be used with this mount. Select one that is equivalent or larger in size than the one originally installed on your vehicle. The larger the filter used, the greater the filtration capacity and the longer the filter life. Space available under the hood is a key consideration. Use the dimension information below as well as the data in diagram A to assist you in selecting a filter.

AMSOIL Full-flow filters	DIA.	Height
EaO-26	3.66"	6.85"
EaO-15	3.66"	5.35"
EaO-96	3.66"	4.21"
EaO-42	3.66"	3.95"
EaO-34	3.02"	4.72"
EaO-57	2.92"	3.40"
EaO-10	2.69"	3.40"

## C. Attaching the filter mount

1. Survey the engine compartment for possible mounting locations. The mount should be located as close to the existing full-flow filter as possible. Solid structures such as the firewall, fender well, or radiator support or frame are common locations. **(Do not mount on engine)** Refer to diagram A for minimum area requirements and consider accessibility for servicing.
2. Refer to diagram B for preferred mounting angle positions.
3. When the location has been determined, use the mounting template provided to locate and mark mounting holes. This can be easily done with a center punch and hammer.

4. Install two "O" ring adapter fittings (BP-189) on filter mount (BK-204) using provided thread sealant as noted in diagram E. If desired, optional 90° angle fittings (BK-11) or 45° angle fittings (BK-12) may also be used. Sold in packages of two, they are available from AMSOIL INC. Using a 57 92(8) Tj/F4 1 Tf8.2 0 0 8.2230.1219014.7777angl(()) Tj-0.0001 Tc0.0169 Tw0 TL/F2 1 Tf0.92970 Td wrenchd, eighteen to40 -4B fo

3. Set vehicle parking brake. With transmission in park/neutral start the engine and immediately check oil pressure. **Note:** Pressure may initially take a moment or two to rise.

**Caution:** Carefully check for leaks at fittings, hoses and mount. If leaks are observed, **STOP ENGINE IMMEDIATELY**, repair leaks and continue.

4. After engine has warmed, shut off and re-check engine oil level. Fill as necessary.  
5. Record vehicle mileage/operating hours and date of installation.

### G. Periodic maintenance

1. Periodic visual inspection of the fittings and hoses is recommended. Look for leaks, hose deterioration and cuts. Repair and/or replace as necessary.
2. Refer to Recommended Filter Change Interval chart for servicing intervals.
3. To change the filter element:
  - a. Ensure engine is off and use caution as the engine, oil and filter may be hot and could result in an injury.
  - b. Using a filter wrench, remove the filter element. Dispose of properly.
  - c. Clean the filter gasket contact area on the mount with a clean, lint-free rag.
  - d. Lubricate the new filter gasket with clean oil or grease.
  - e. Fill filters as full as possible with engine oil.
  - f. Screw on new filter, tighten per instructions on filter can.
  - g. Start engine and check for leaks.
  - h. Check engine oil level, fill as needed.
4. Record vehicle mileage/operating hours for future reference.

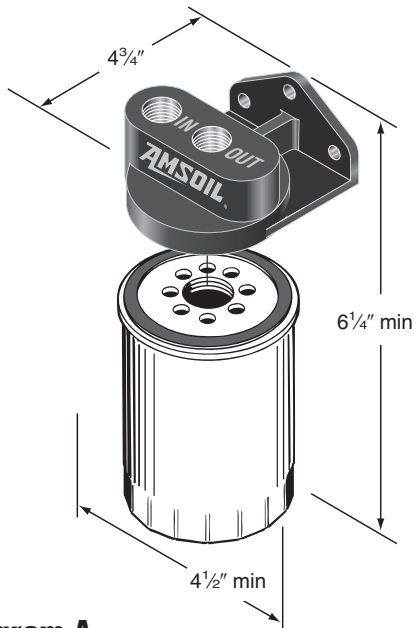
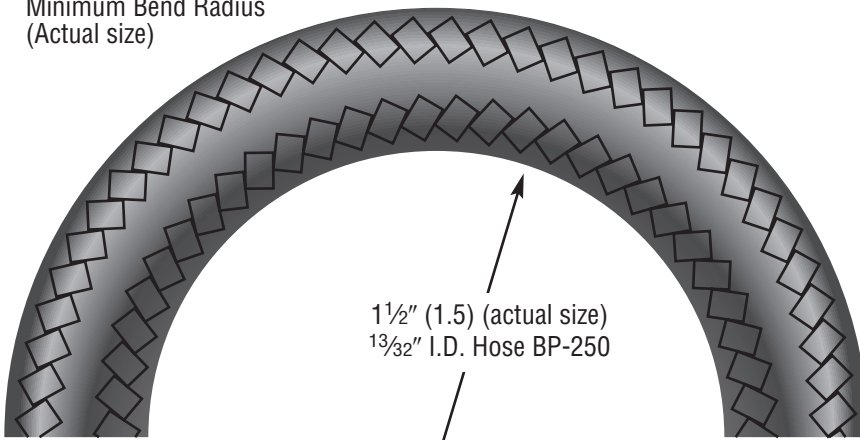

**Diagram A**

MINIMUM AREA NEEDED FOR REMOTE MOUNT FITTINGS, AND SMALLEST SPIN-ON OIL FILTER ELEMENT.

### Diagram C

Minimum Bend Radius  
(Actual size)



### Parts and assembly list

Item	Description	Qty.	Part No.
1.	Filter Mount Assembly, Spin-On	1	BK-204
2.	"O" Ring Fitting Adapter 3/4"-16 x 1/2" J.I.C.	2	BP-189
3.	Adapter Fitting 3/8" N.P.T. x 1/2" J.I.C.	2	BP-190
4.	5/16" Fender Washer	3	BP-205
5.	5/16" Flat Washer	3	BP-120
6.	5/16"-18 Self Locking Nut	3	BP-121
7.	5/16"-18 x 1" Hex Head Bolt	3	BP-122
8.	1 3/32" I.D. Hose	8'	BP-250
9.	Hose Fitting	4	BP-260
10.	Spin-On Filter Adapter	1	BP-159
11.	"O" Ring Small	1	BP-196
12.	"O" Ring Casting	1	BP-160
13.	"O" Ring Large	1	BP-162
14A.	Thread Adapter 3/4"-16 (white)	1	BP-163
14B.	Thread Adapter 1 3/16"-16 and 20 mm-1.5 mm (blue)	1	BP-164
14C.	Thread Adapter 18mm-1.5 mm (red)	1	BP-165
14D.	Thread Adapter 22mm-1.5 mm (yellow)	1	BP-166
	Plastic Tie	2	BP-46
	Thread Sealant	1	BP-198
	Instruction Sheet	1	BP-173
Optional Parts Available From AMSOIL INC.			
	90° Fitting, Pack of 2		BK-11
	45° Fitting, Pack of 2		BK-12

### Mounting Angle Diagram B

(Recommendations are the same right to left and front to back)  
Mounting angle above horizontal is not recommended

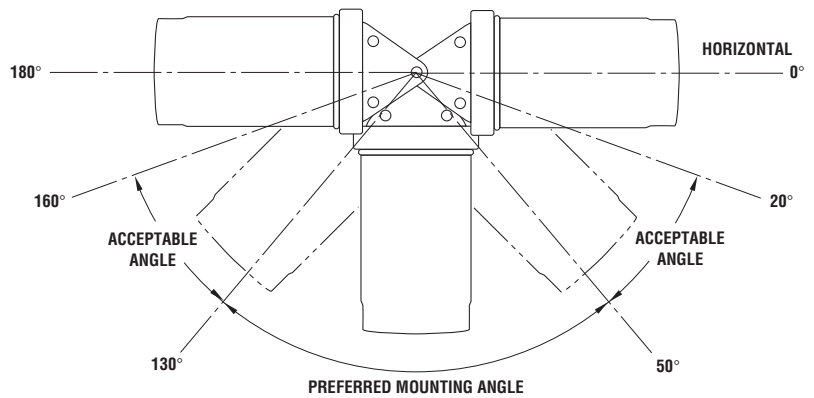

### Mounting Template

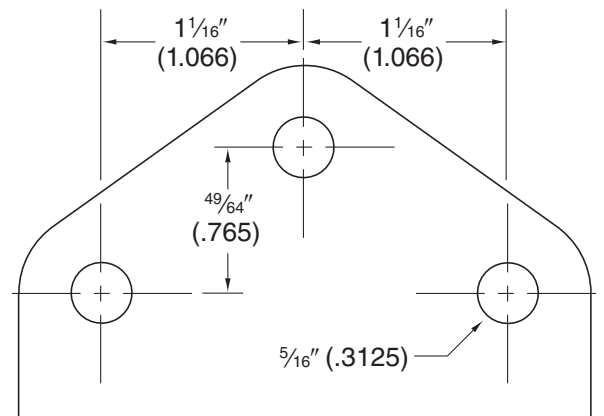

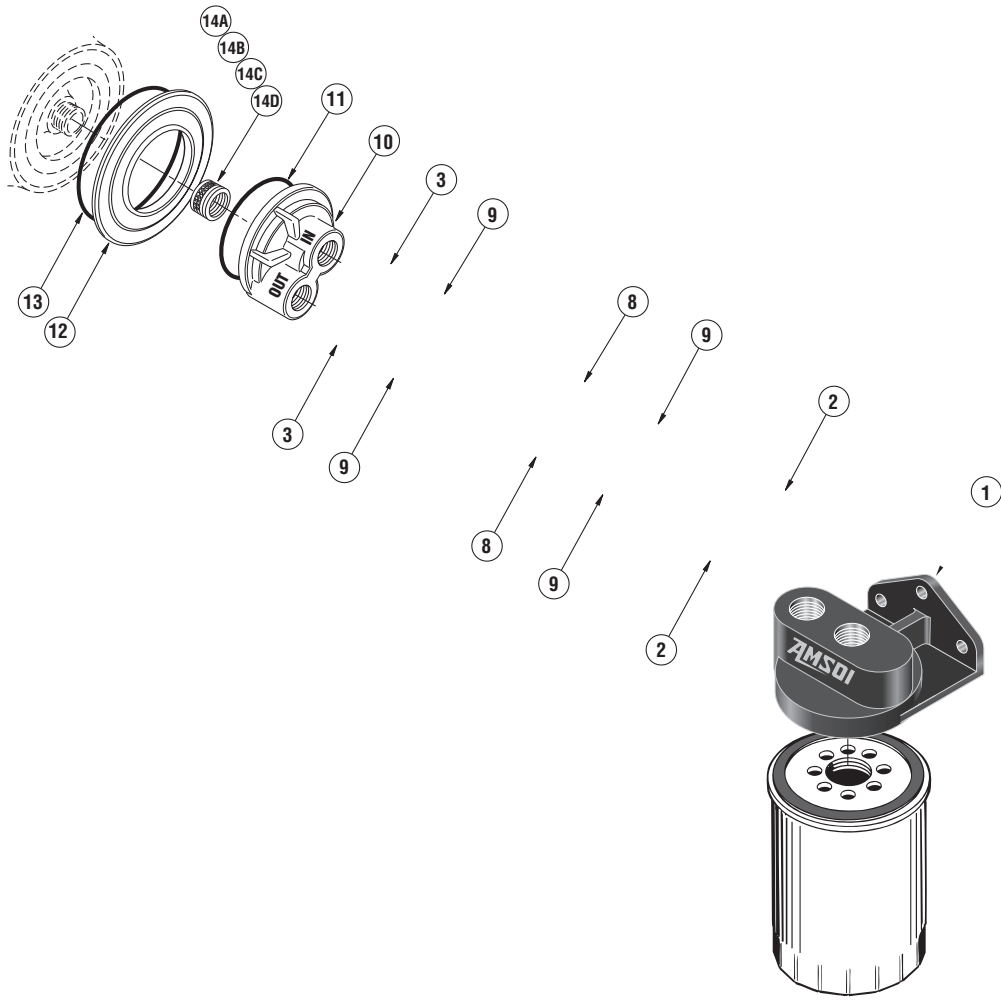

# BMK-14 PAGE TWO

(1) BP-196



SMALL "O" RING  
2½" I.D.

(1) BK-204

FILTER MOUNT

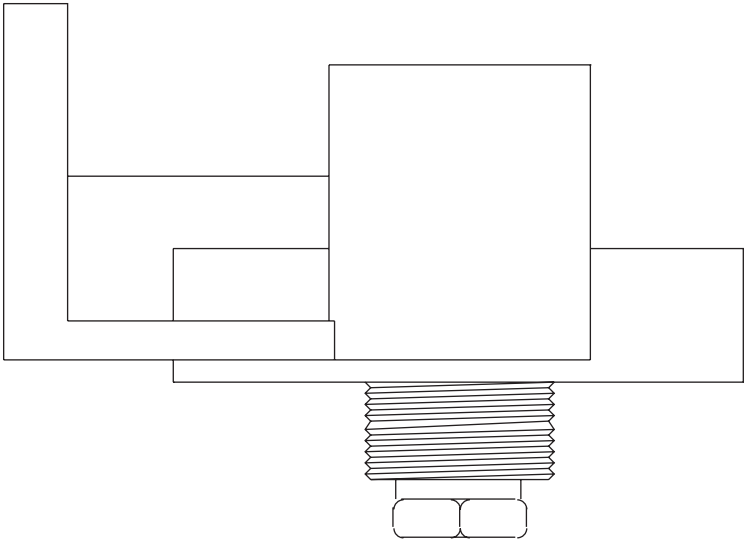

(3) BP-205

5/16" FENDER  
WASHER

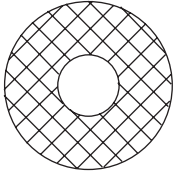

# BMK-14 PARTS IDENTIFICATION SHEET

(2) BP-46   
 PLASTIC TIE

(1) BP-165   
 ADAPTER RED  
 18 mm - 1.5 mm

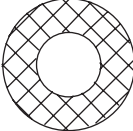
(3) BP-120   
 5/16" WASHER

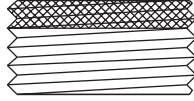
(1) BP-166   
 ADAPTER YELLOW  
 22 mm - 1.5 mm

(3) BP-121   
 5/16" NUT

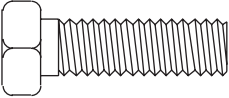
(3) BP-122   
 5/16" x 1" BOLT

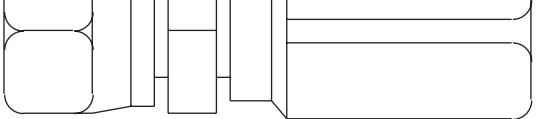
(4) BP-260   
 HOSE FITTING

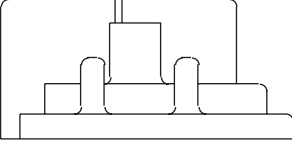
(1) BP-159   
 FILTER ADAPTER  
 NOT TO SCALE

(8) BP-250   
 13/32" HOSE

(1) BP-160   
 "O" RING CASTING  
 NOT TO SCALE

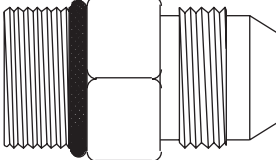
(2) BP-189   
 "O" RING  
 FITTING  
 ADAPTER

(1) BP-162   
 LARGE "O" RING  
 3 3/8" I.D.  
 NOT TO SCALE

(1) BP-163   
 ADAPTER WHITE  
 3/4" - 16

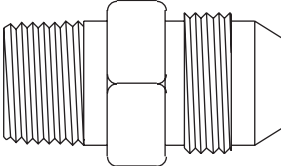
(2) BP-190   
 ADAPTER  
 FITTING

(1) BP-164   
 ADAPTER BLUE  
 13/16" - 16  
 20 mm - 1.5 mm

## Diagram H Hose routing examples

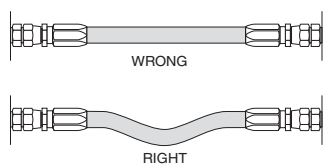

### 1. Provide for length change

In straight hose installations allow enough slack in the hose line to provide for changes in length that will occur when pressure is applied. This change in length can be from +2% to -4%.

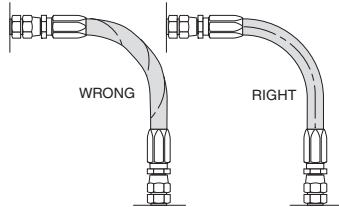

### 2. Avoid twisting and orient properly

Do not twist hose during installation. This can be determined by the printed layline on the hose. Pressure applied to a twisted hose can cause hose failure or loosening of connections.

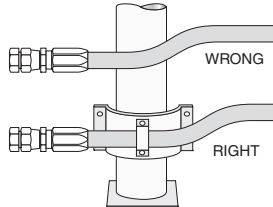

### 3. Protect from hazardous environment

Keep hose away from hot parts. High ambient temperature will shorten hose life. If you can not route it away from the heat source, insulate it.

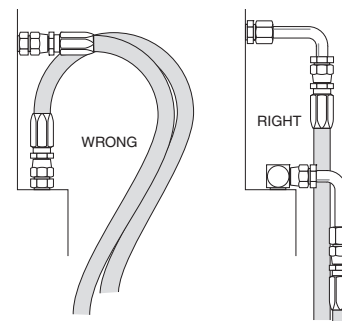

### 4. Avoid mechanical strain

Use elbows and adapters in the installation to relieve strain on the assembly, and to provide easier and neater installations that are accessible for inspection and maintenance.

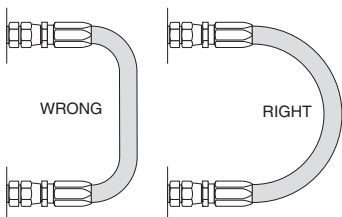

### 5. Use proper bend radius

Keep the bend radius of the hose as large as possible to avoid collapsing of the hose and restriction of flow. Follow catalog specs on minimum bend radii.

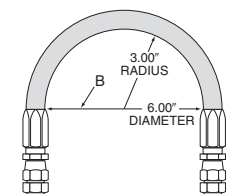

### 6. Use proper bend radius (cont.)

Maximum bend radius is measured on the inside bend of the hose. To determine minimum bend, divide the total distance between ends (B length) by 2. For example B = 6, minimum bend radius = 3.

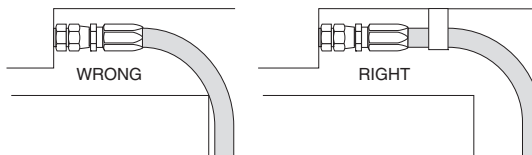

### 7. Secure for protection

Install hose runs to avoid rubbing or abrasion. Use clamps to support long runs of hose or to keep hose away from moving parts. It is important that the clamps do not allow the hose to move. This movement will cause abrasion and premature hose failure.

### 8. Avoid Improper Hose Movement

Make sure relative motion of the machine components produces bending rather than twisting of the hose. Hose should be routed so that the flex is in the same plane as the equipment movement.

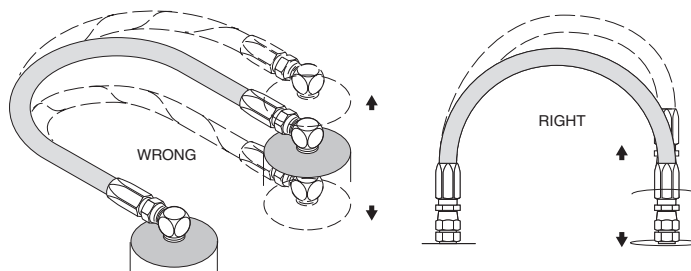

## AMSOIL Filter Change Recommendations Lube Filters

### Vehicles with Gasoline or Diesel Fueled Engines

- **EaO and Donaldson Endurance ELF 7349** (Dodge Cummins 5.9L): Change filter at time of oil change up to 25,000 miles or one-year service life, whichever comes first, when used in conjunction with AMSOIL Synthetic Motor Oil.
- **Donald Endurance:** Heavy-duty commercial vehicles and off-road equipment, when used in conjunction with AMSOIL Synthetic Motor Oil, change filter up to two times longer than OEM\* recommendations, not to exceed 60,000 miles for on-highway diesel applications. Always change oil filter at the time of oil change.
- **WIX and Donaldson P Series:** OEM recommendations.

### Stationary Engines

- **EaO and Donaldson Endurance:** up to two times longer than OEM\* recommendations. Always change oil filter at time of oil change.
- **WIX and Donaldson P Series:** OEM\* recommendations.

\*Original Equipment Manufacturer

To order By-Pass Oil Filter Parts or oil sample kits, consult your AMSOIL Dealer or the AMSOIL Product Price List for your country. Most of these items are available from your AMSOIL Product Center.